

C-TOOL version 1.1

**A TOOL FOR SIMULATION OF SOIL CARBON
TURNOVER**

Description and users guide

Bjørn Molt Petersen

June 2003

Danish Institute of Agricultural Sciences

Department of Agroecology

Research Centre Foulum

P.O. Box 50, DK-8830 Tjele

Denmark

Contents

- 1. Introduction**
- 2. Model description**
 - 2.1. Carbon pools**
 - 2.2. Rate and allocation modifiers**
 - 2.3. Isotope simulation**
 - 2.4. Steady level**
- 3. Input files**
 - 3.1. Mandatory input files**
 - 3.1.1. Control file**
 - 3.1.2. Model structure file**
 - 3.1.3. Initialisation file**
 - 3.1.4. Added organic matter file**
 - 3.1.5. Supply file**
 - 3.2. Optional input files**
 - 3.2.1. Microclimate file**
 - 3.2.2. Radiocarbon file**
- 4. Output files**
- 5. Installation and execution of the program**
 - 5.1. Installation**
 - 5.2. Execution**
- 6. Execution examples for 3-pool model**
 - 6.1. Input file examples**
 - 6.2. Execution results**
- 7. Execution examples for CN-SIM**
- 8. References**

1. Introduction

The program C-TOOL (v. 1.1) can enhance SOM model development by aiding the construction, revision and testing of soil carbon turnover models. Models can be created directly, without the aid of programmers. The program can use any time step between one day and one year, and can be run either for a predefined period or continue until specified steady-level criteria for carbon pools are reached. Development in soil carbon content at any desired time span can be simulated.

Simulation of carbon isotopes ^{13}C and ^{14}C is facilitated, and it is possible to simulate a specific isotope tagging in order to investigate carbon flow properties in the implemented model.

Standard driving variables are temperature (in air or soil), soil water content (either absolute content, relative content or pressure potential) and amount, type and application date for input of carbon to the soil.

All settings are performed through ascii-files, and not through screen dialogs.

2. Model description

A description of the scientific rationale behind this software is provided by (Petersen *et al.*, 2002).

2.1. Carbon pools

The decay of carbon in each pool is described by first-order reaction kinetics

$$\frac{dC_i}{dt} = -k_i C_i \quad (1)$$

where k_i is the decay rate coefficient for pool i (time^{-1}), and C_i is the carbon content in pool i (amount). The specific unit will depend on the actual model specification.

The model is by default updated in discrete steps (Euler integration) by subtracting $D_i \Delta t$ from C_i , where Δt is the time step (time). The decay rate D_i of pool i (amount C time^{-1}) is by default calculated as

$$D_i = k_i C_i \quad (2)$$

As an option set by the user, the decay rate can alternatively be calculated as

$$D_i = C_i [1 - \exp(-k_i \Delta t)] \quad (3)$$

An optional fourth order Runge-Kutta integration method is implemented. The use of this will yield better accuracy, at the cost of execution speed. It should only be used in combination with Eq. 2, not with Eq. 3.

The preferable method depends on the specific application and the time step. Under most circumstances, the difference between the methods will be negligible with a daily time-step, but with larger time-steps the Runge-Kutta integration in many cases may be preferable.

Three types of SOM-pools are distinguished: 1) added organic matter, 2) microbial biomass, and 3) native soil organic matter.

Microbial biomass pools have additional maintenance (M_i) and utilisation efficiency (E_i) components. The fraction $1-E_i$ of the incoming carbon is lost from the system as CO₂. The maintenance (CO₂ loss) is calculated by Eq. 2 or 3, substituting k_i with M_i .

Added matter pools have associated sub-pools with decay rates that can depend on the type of added matter.

The calculations within each time step are made in the following order: 1) the decay of all pools is calculated, 2) the decay is directed to other pools and/or lost as CO₂ as specified by the model structure file.

2.2. Rate and allocation modifiers

The decomposition rate can be set to depend on several abiotic and biotic functions. The standard set up is:

$$k_i = k_i^s F_T(T) F_W(W) F_X(X) \quad (4)$$

where k_i is the actual decay rate for pool i (time⁻¹), k_i^s is the decay rate (time⁻¹) at standard conditions, F_T is a function of temperature T (°C), F_W is a function of soil water content W , and F_X is a function of clay content X (fraction). Any of the three modifier functions in Eq. 4 can optionally be left out.

The standard temperature dependency (after Kirschbaum, 1995), is

$$F_T(T) = A \exp[\alpha + \beta T(1 - 0.5T/T_m)] \quad (5)$$

where A (dimensionless) by default is adjusted to give unity output at 10 °C, α has a default value of -3.432, β has a default value of 0.168 °C⁻¹, and T_m has a default value of 36.9 °C.

Alternative temperature dependencies are Arrhenius (Eq. 6), Van't Hoff (Eq. 7), one taken from Hansen *et al.* (1990) (Eq. 8), and one taken from Coleman and Jenkinson (1996) (Eq. 9).

$$F_T(T) = A \exp\left(\frac{\omega(T - T_r)}{(T + 273.2)(T_r + 273.2)}\right) \quad (6)$$

Default values are: ω : 6352.0 °K, T_r : 30.0 °C, A (dimensionless) is default adjusted to give unity output at 10 °C.

$$F_T(T) = A Q_{10}^{(T - T_r)/10} \quad (7)$$

Q_{10} represents the increase in the turnover rate for a temperature increase of 10°C, default value 2, A (dimensionless) is default adjusted to give unity output at 10 °C.

$$F_T(T) = \begin{cases} 0 & T \leq 0 \\ 0.1AT & 0 > T \leq 20 \\ A \exp(0.47 - 0.027T + 0.00193T^2) & T > 20 \end{cases} \quad (8)$$

By default A (dimensionless) is 1.

$$F_T(T) = \begin{cases} 0 & T \leq -18.3 \\ A \frac{47.9}{1 + \exp\left(\frac{106}{T + 18.3}\right)} & T > -18.3 \end{cases} \quad (9)$$

By default A (dimensionless) is 1.

The soil water function (after Johnsson *et al.*, 1987) is calculated as

$$F_W(W) = \begin{cases} \gamma_1 & W \leq W_1 \\ \gamma_1 + (1 - \gamma_1) \left(\frac{W - W_1}{W_2 - W_1}\right)^m & W_1 < W \leq W_2 \\ 1 & W_2 < W \leq W_3 \\ 1 - (1 - \gamma_2) \left(\frac{W - W_3}{W_4 - W_3}\right)^m & W_3 < W \leq W_4 \\ \gamma_2 & W_4 < W \end{cases} \quad (10)$$

where W is relative soil water content (%), W_1 is relative soil water content at permanent wilting point (%), W_2 is relative soil water content at the permanent wilting point + 10%, W_3 is relative soil

water content at saturation – 8%, W_4 is relative soil water content at saturation (%), γ_1 is 0, γ_2 is 0.6, and m is 1.

The default function to calculate the effect of clay content on SOM decay (after Hansen *et al.*, 1990) is:

$$F_X(X) = \begin{cases} 1 - \frac{1-b}{X_l} X & X \leq X_l \\ b & X > X_l \end{cases} \quad (11)$$

where X_l has a default value of 0.25 (kg kg⁻¹), and b has a default value of 0.5.

As an alternative to Eq. 11, the allocation between carbon lost as CO₂ and carbon directed to other pools can be altered as a result of the clay effect, following Coleman and Jenkinson (1996)

$$R_X(X) = a_1 + a_2 \exp(a_3 X) \quad (12)$$

where R_X is the ratio (CO₂ loss)/(loss to other pools).

Default values are: $a_1 = 3.0895$; $a_2 = 2.672$; $a_3 = -7.86$.

The soil clay function value can also be given directly in the initialisation file, overwriting values from Eq. 11 or Eq. 12.

The specific model “CN-SIM” (Fig. 7.1), which is calibrated on the basis of a large number of experiments (Petersen *et al.*, 2003), can also be implemented in C-TOOL. In this model, the soil clay content is assumed to have a double effect: 1) on the longevity of soil microbial biomass, and 2) on the "humification coefficient". The humification coefficient h is defined as the fraction of C in the organic input that ends up in the slowly decaying NOM pool.

The first effect of the clay content is assumed to modify both the decay and respiration rates of the soil microbial biomass, according to Eq. 11.

The second clay response, which affects the “humification coefficient” h , is based on Eq. 12. The “humification coefficient” h is given as

$$h = 1/(R + 1) \quad (13)$$

For a given clay content, which yields a specific value for h , the humification is adjusted by adjusting the ratio between maintenance rate and death rate for the two pools of CN-SIM, in the manner further described in Petersen *et al.* (2003).

The humification for animal manure is assumed to be higher than for plant matter, as a part of added animal manure C is assumed to go directly to the NOM pool (Fig. 7.1). For plant matter, no C is assumed to go directly to the NOM pool.

2.3. Isotope simulation

The isotopes ^{13}C and ^{14}C can optionally be simulated. Model input and output can be given as relative difference:

$$\delta_z = 1000 \frac{R_z - R_{ZS}}{R_{ZS}} \quad (14)$$

where δ_z is the relative difference of isotope Z ($^{\circ}/_{00}$), and R_z and R_{ZS} are the ratios of rare to common isotope of respectively the sample and the laboratory standard.

The relationship between the modelled content of the isotope in question in a pool, Z_i , and the ratio R_{Zi} is defined as

$$R_{Zi} = \frac{\frac{Z_i R_{ZS}}{1 + R_{ZS}}}{C_i - \frac{Z_i R_{ZS}}{1 + R_{ZS}}} \quad (15)$$

where Z_i is directly proportional to the amount of the isotope in pool i , and when Z_i equals C_i (carbon content in pool i), δ_{Zi} is zero.

The default value of $R_{ZS} = 0.0112372$ for ^{13}C applies to the PDB standard.

The decay of the radioactive ^{14}C isotope is calculated as

$$\lambda'_i = \lambda_i \exp\left(\frac{\Delta t_h \ln(0.5)}{H}\right) \quad (16)$$

where λ_i is the ^{14}C content in pool i (defined analogous to Z_i in Eq. 15) before decay, λ'_i is the ^{14}C content in pool i after decay, Δt_h (years) is the time step for radioactive decay (one year), and H is the half-time for ^{14}C , default value 5568 years. ^{14}C is so rare relative to ^{12}C , that R_{ZS} is set to zero for this isotope.

Input and output for ^{14}C values can optionally be specified as percent modern (pM), calculated as

$$pM = 100 \frac{\sum_{i=1}^n \lambda_i}{\sum_{i=1}^n C_i} \quad (17)$$

where n is the number of pools.

The soil radiocarbon age, Q (years), is calculated as

$$Q = \frac{H \ln \left(\frac{\sum_{i=1}^n \lambda_i}{\sum_{i=1}^n C_i} \right)}{\ln(0.5)} \quad (18)$$

A table with historic atmospheric radiocarbon data in the northern hemisphere (Fig. 3.2.2.1) is provided with the program.

As ^{14}C is assumed to be fractionated twice as much as ^{13}C , it is common to normalise ^{14}C measurements using the $\delta^{13}\text{C}$ value in the following approximation

$$\Delta^{14}\text{C} = \delta^{14}\text{C} \left(1 - \frac{2(\delta^{13}\text{C} + 25)}{1000} \right) \quad (19)$$

Hereby only samples with $\delta^{13}\text{C} = -25 \text{ ‰}$ (postulated mean value for terrestrial wood) will have $\Delta^{14}\text{C} = \delta^{14}\text{C}$.

These corrections should be made prior to comparisons with model outputs.

The original standard for ^{14}C was wood grown in 1950, but the more operational standard of 95% of the $^{14}\text{C}/^{12}\text{C}$ ratio of the NBS oxalic acid sample, *in AD 1950*, is now used as the reference activity. Note that this defines an *absolute* ^{14}C activity, and that data also frequently are reported in terms of *relative* activity, using the associated symbols $d^{14}\text{C}$ (prior to normalisation with $\delta^{13}\text{C}$), and $D^{14}\text{C}$ (after normalisation). Values entering C-TOOL, or used for comparison with model outputs, should be converted either to "absolute" percent modern values (*sensu* Stuiver and Polach, 1977), or to $\Delta^{14}\text{C}$ values. Conversion equations are given in Stuiver and Polach (1977).

Testing internal model flow properties is facilitated by simulated isotope tagging with ^{13}C . It can be specified for each pool, that all carbon leaving should be either tagged ($\delta^{13}\text{C} = 0$) or untagged ($\delta^{13}\text{C} = -1000$). See section 6.1 for an example.

2.4. Steady level

The model can either be run for a predefined number of years, or until a steady level (*sensu* Petersen *et al.*, 2002) is reached. Steady level is reached when a repeated cycle is occurring during each repeated sequence. When computing steady level, the time sequence defined by files for soil conditions and added matter is repeated until the steady level condition is fulfilled. Eq. 20 and optionally Eq. 21 are invoked by the end of each repeated time sequence.

Steady level is assumed to be reached when the following condition is fulfilled

$$\sqrt{\sum_{i=1}^n (\Delta C_i)^2} / \sqrt{\sum_{i=1}^n C_i^2} < c \quad (20)$$

where ΔC_i is the change in carbon content of pool i since the end of last sequence, c is a constant (dimensionless) with a default value of 10^{-9} , and n is number of pools. If isotopes are simulated, the following condition must also be fulfilled

$$\sqrt{\sum_{i=1}^n (\Delta Z_i)^2} / \sqrt{\sum_{i=1}^n Z_i^2} < d \quad (21)$$

where ΔZ_i is the change in isotope Z content of pool i since the end of last sequence, and d is a constant (dimensionless) with a default value of 10^{-9} .

When computing steady level with ^{14}C , it is assumed that $\Delta^{14}\text{C}$ is zero for all added carbon.

3. Input files

All settings of structure, time step e.g. are performed through a number of ASCII-files.

In order to minimise redundant files, the input files are first looked for in the input directory. If the file in question is not found here, the program will continue to change directory one step up until either the file is found, or the root directory is reached. This facilitates placement of files that are common for a number of simulations highest in the directory hierarchy, and files that are unique for a given simulation or implementation lowest in this hierarchy.

The spelling and upper/lower case in the files must be exactly as specified!

3.1. Mandatory input files

Mandatory input files are: the *control file*, the *model structure file*, the *initialisation file*, the *added organic matter file* and the *supply file*.

Examples of input files can be seen in sections 6.1 and 7.1.

3.1.1. Control file

The *control file* specifies the number of simulations to be performed during a program execution, and specifies which specimen of the files stated below that is associated with each execution. The file name must be "setup.dat".

The control file can be placed in the directory "`c-tool-v1_1\`". Alternatively, a call parameter can contain the name of the directory where the control file is placed. This is most convenient done with a batch file, see section 6.1 for an example.

Each section, corresponding to one simulation, starts with the section heading "`[run(i)]`" with consecutive numbering, starting with zero. Each section is terminated with a line starting with the symbol "`[`". This could either be a new section, or a mandatory "`[end]`", which terminates further reading of the file. Each parameter and its value must occupy one separate line.

Mandatory parameters

`InputDirectory` gives the directory where the input files are read.

`OutputDirectory` gives the directory where the output files are written.

`SupplyFile` gives the name of the file that specifies date, type and amount of added carbon.

`StructureFile` gives the name of the model structure file.

`AddTypeFile` gives the name of the added organic matter file, which contains characteristics of all possible types of input.

`ConditionFile` gives the name of the file with initial conditions.

Optional parameters

`StartYear`, year where the simulations starts.

`EndYear`, year where the simulations stops.

`DetailFile`. If included, a file with the stated name will be written, containing more detailed information than the default output file "results.txt".

`MaxIterations`. If included, the simulation will continue until either a steady level (defined by Eq. 20 and optionally Eq. 21) is reached, or `MaxIterations` simulations have been carried out. If a steady level should not be reached, this will be written in the file "endstate.txt".

`MaxDeltaCarbon` corresponds to the parameter c in Eq. 20.

`MaxDeltaIsotope` corresponds to the parameter d in Eq. 21.

`MonthStep` gives the step length in months. Should only be specified, when no microclimate-file is specified. Integer 1-12.

`DayStep` gives the step length in days. Should only be specified, when no microclimate-file is specified. Integer 1-365.

If no microclimate-file is specified, a step length must be given, as well as both start year and end year.

"IsotopeType". Possible input 1-3. 1: ^{13}C ; 2: ^{14}C ; 3: Tagging. See section 6.1 for examples.

"YearlyOutput". "N" (default): write to output files for each step. "Y": Only write to output files once a year. See also *"WriteMonth"*.

"WriteMonth". If *YearlyOutput* is set, determine which month output is written at the 1st (1-12). Default value 1.

"MonthlyOutput". "N" (default): write to output files for each step. "Y": Only write to output files at the 1st each month.

"UseAverageClimate". "N" (default): soil climatic conditions for each time-step in the entire simulation period must be available. "Y": average climatic conditions for one year is repeated for the entire simulation.

"UseAverageAmounts". "N" (default): single carbon inputs for entire simulation period must be available. "Y": average inputs for one year is repeated for the entire simulation.

"UsePercentModern". "N" (default): use $\Delta^{14}\text{C}$ values for radiocarbon input and output. "Y": use Percent Modern for radiocarbon input and output.

"Rzs". Change the value of R_{zs} (Eqs. 14 and 15) for ^{13}C . Default value 0.0112372 (PDB).

"SupplyFileWith14C". "N" (default): use ^{14}C values as given for each year in the radiocarbon file. "Y": supply ^{14}C values as an extra input for each line in the supply file.

"UseRungeKutta". "N" (default): use one integration step per time-step. "Y": use the fourth-order Runge-Kutta integration method.

"WriteCO2PerStep". "N" (default): output the cumulated CO_2 -release. "Y": output values for CO_2 -release per step.

3.1.2. Model structure file

The *model structure file* specifies model structure and parameters. The name of this file is given by the control file.

Each section, corresponding to one pool, starts with a section heading enclosed by "[" and "]".

Sections must have consecutive numbering, starting with zero. Each section is terminated with a line starting with the symbol "[". This could either be a new section, or a mandatory "[end]", which terminates further reading of the file.

Mandatory parameters for each pool

A section heading, either "[*AddedMatter(i)*]", "[*BioMatter(i)*]" or "[*Matter(i)*]", The type of pool is given by this heading.

"*Name*". Specifies the pool name.

"*DecompositionRate*". Specifies decomposition rate *per step length*, only used for "[*AddedMatter(i)*]" or "[*Matter(i)*]".

"*Direction(j)*". A direction for outflux from the pool (consecutively numbered). This must either be another pool, or "*CO2*". Must be numbered consecutively, starting with zero.

"*Fraction(j)*". Corresponds to the above parameter. The fraction of the total outflux that is directed towards this pool.

Pools with the heading "[*BioMatter(i)*]", must contain the parameters below.

"*UtilizationEfficiency*", notated *E*. The product of *E* and the ingoing carbon will be utilised in the pool, the rest will be lost as CO₂. Range: 0-1.

"*Maintenance*". Analogous to *k* in Eq. 1, but the decay is exclusively lost as CO₂. Rate *per step length*.

"*DeathRate*". Analogous to *k* in Eq. 1, and the decay is directed to other pools as specified. Rate *per step length*.

Optional parameters for each pool

"*UseClayEffect*". "*N*" (default): do not use clay effect in this pool. "*Y*": use clay effect in this pool.

"*ExponentialDecay*". "*N*" (default): perform decay according to Eq. 2. "*Y*": perform decay according to Eq. 3. "*Y*" is not recommended in combination with the Runge-Kutta method.

"*TAG*". "*0*": Untag all carbon going out from this pool. "*1*": Tag all carbon going out from this pool. See an example in section 6.1.

Optional parameters, not pool specific

This section must start with the heading "[*Parameters*]".

"*TemperatureResponse*". "*0*": Temperature response not considered (value always unity). "*1*":

"Kirschbaum" response (Eq. 5) - default adjusted to unity at 10 °C. "*2*": "RothC" response (Eq. 9.).

"*3*": "DAISY" response (Eq. 8.). "*4*": "Arrhenius" response (Eq. 6.) - default adjusted to unity at 10

°C. "5": "Van't Hoff" response (Eq. 7.) - default adjusted to unity at 10 °C. "6": Value read directly from microclimate file. The calculated values can be overwritten in the initialisation file, see *"TemperatureEffect"*.

"TemperatureAdjust". Corresponds to A in Eqs. 5-9. Default adjusted so that Eqs. 5, 6 and 7 give unity output at 10°C. When using Eq. 8 or 9, the default value is 1.

"Kirschbaum1" corresponds to α in Eq. 5. Default value -3.432.

"Kirschbaum2" corresponds to β in Eq. 5. Default value 0.168.

"KirschbaumTopt" corresponds to T_m in Eq. 5. Default value 36.9.

"Arrhenius" corresponds to ω in Eq. 6. Default value 6352.

"VantHoffQ10" corresponds to Q_{10} in Eq. 7. Default value 2.

"ReferenceTemperature" corresponds to T_r in Eqs. 6 and 7. Default value 30.

"WaterResponse". "0": Water response not considered (value always unity). "1": Value computed according to Eq. 10. "2": Value read directly from microclimate file. The calculated values can be overwritten in the initialisation file, see *"WaterEffect"*.

"W2Offset". Used to compute W_2 in Eq. 10, $W_2 = W_1 + W2Offset$. Default value 10.

"W3Offset". Used to compute W_3 in Eq. 10, $W_3 = W_4 + W3Offset$. Default value -8.

If W_3 becomes smaller than W_2 after applying the above, the program will halt with an error message.

"Y1". Corresponds to γ_1 in Eq. 10. Default value 0.

"Y2". Corresponds to γ_2 in Eq. 10. Default value 0.6.

"m". Corresponds to m in Eq. 10. Default value 1.

"ClayResponse". "0": Clay response not considered (value always unity). "1": Following Eq. 11 ("DAISY" response). "2": Calculated according to Eq. 12 ("RothC" response). "3": Calculated according to the "CN-SIM" model.

"ClayContentLimit". Corresponds to X_l in Eq. 11.

"ClayRateLimit". Corresponds to b in Eq. 11.

"ClayParameter1". Corresponds to a_1 in Eq. 12.

"ClayParameter2". Corresponds to a_2 in Eq. 12.

"ClayParameter3". Corresponds to a_3 in Eq. 12.

"HalfTime". The halving time for ^{14}C (H in Eqs. 17 and 19). Default value 5568 years.

3.1.3. Initialisation file

The *initialisation file* specifies initial conditions such as carbon content and optionally isotope content in each SOM pool. There are no "sections" in this file, as was the case for the preceding files, but it still must be terminated with "[end]".

"*TotalC*" The total carbon content in the soil in question in any desired unit.

"*MinContent*". Corresponds to W_1 in Eq. 10. Default value 5.

"*MaxContent*". Corresponds to W_4 in Eq. 10. Default value 50.

"*ClayContent*". Fraction of the soil dry weight that consists of clay. Possible range 0-1.

"*ClayEffect*". Direct input of clay effect, given as any positive number. This overwrites function values.

"*TemperatureEffect*". Direct input of temperature effect, given as any positive number. This overwrites function values.

"*WaterEffect*". Direct input of water effect, given as any positive number. This overwrites function values.

For each pool with initial carbon content above zero, the name of the pool corresponding to a name in the structurefile (referred to as ***PoolName***) must be given succeeded by the fraction of the total carbon it contains, see examples in section 6.1. These fractions must add to one.

"***PoolName.d13C***". The $\delta^{13}\text{C}$ value of the pool carbon. Default value 0.

"***PoolName.PM***". The radiocarbon content of the pool given in percent modern. Default value 100.

"***PoolName.d14C***". The $\Delta^{14}\text{C}$ content of the pool carbon. Default value 0.

"***PoolName.TAG***". The content of "tagged" matter in the pool. Input values 0-1. Default value 0.

3.1.4. Added organic matter file

The *added organic matter file* gives the characteristics of each possible input (straw, root matter, farmyard manure etc.). The name of this file is read from the control file. Each section, corresponding to one type of input, starts with a section heading. Sections must have consecutive numbering, starting with zero. Each section is terminated with a line starting with the symbol "[". This could either be a new section, or a mandatory "[end]", which terminates further reading of the file.

"*OrganicProduct(i)*". This is the section heading.

"*Name*". Name of the product in question.

"*Pool(j)*". Name of the pool that this fraction of the carbon enters. This name must either correspond to one of the names in the structure-file, or be "*CO2*". Must be numbered consecutively, starting with zero.

"*Fraction(j)*". Fraction of the carbon that enters the pool given above.

"*DecayRate(j)*". Optional parameter. If not set, the rate from the model structure file is used. This parameter will only have effect if the referred pool is of the type "added matter", the only type that can have several associated sub-pools with different decay rates.

3.1.5. Supply file

The *supply file* (driving variables) specifies date, amount and optionally isotope content of carbon inputs. The name of this file is read from the control file. Supplies can optionally be given as average amounts.

For each line, data must be in this order:

Year¹⁾, month, day, name of product²⁾, amount, isotope content³⁾

¹⁾ Not used if "UseAverageAmounts" is set to "Y" in the control file. ²⁾ Name that must correspond to one of the types in the added organic matter file. ³⁾ Optional, can be deselected as described under the control file.

Data must be separated with space(s) or tab(s).

3.2. Optional input files

Optional input files are: the *microclimate file* and the *radiocarbon file*.

3.2.1. Microclimate file

The *microclimate file* (driving variables) specifies temperature and soil water content over a time-span. The name of this file is given by the control file. Microclimate can optionally be given as averages over an one-year period.

If no microclimate-file is specified, a step length must be given, as well as both start year and end year.

For each line, data in the microclimate file must be this order:

Year¹⁾, month, day, temperature²⁾, watercontent²⁾

¹⁾ Not used if "UseAverageClimate" is set to "Y" in the control file. ²⁾ Optional, can be deselected in the manner described under the model structure file.

Data must be separated with space(s) or tab(s).

3.2.2. Radiocarbon file

The *radiocarbon file* (driving variables) specifies postulated atmospheric ¹⁴C content in the northern hemisphere over a time-span. This file ("radiocarb.dat"), which is supplied with the program, must be located under "\c-tool-v1_1\" and should not be modified.

The radiocarbon file was constructed on the basis of data from Baxter and Walton (1971) for the period 1860-1958, Levin *et al.* (1994) for the period 1959-1984, and Levin and Kromer (1997) for the period 1985-1996. Before 1860 the radiocarbon content is assumed to be 100% modern, $\Delta^{14}\text{C} = 0$. Values for 1997-2010 are extrapolated according to Levin and Kromer (1997). The values in the radiocarbon file are in units of "absolute" percent modern (*sensu* Stuiver and Polach, 1977), and should be considered summer means, taken in May to August where direct measurements are available, respectively obtained during the growing season where plant products were used to estimate historic radiocarbon levels.

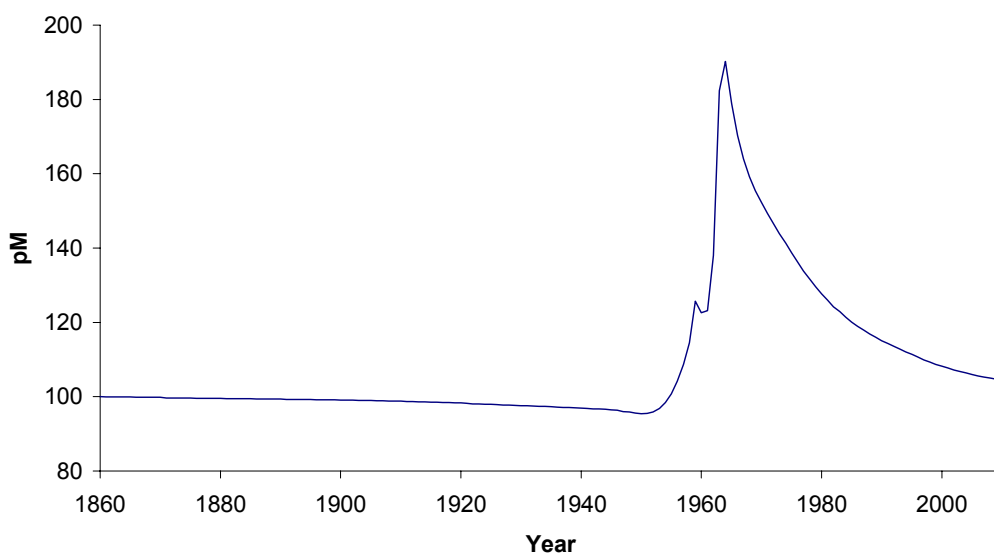

Figure 3.2.2.1. Postulated atmospheric ¹⁴C content in the northern hemisphere.

4. Output files

The *output file* "results.txt" contains tabulator-separated data in the following order:
Year, month, day, total carbon amount, isotope content¹⁾, radiocarbon age³⁾

The *detailed output file* (optional, name set by user) contains tabulator-separated data in the following order:

Year, month, day, for each pool: total carbon amount and isotope content¹⁾, CO₂ evolution²⁾, CO₂ isotope content^{1), 2)}, total carbon amount, total isotope content¹⁾

¹⁾ Only if an isotope is simulated.

²⁾ Either cumulated values (default) or daily values (optional).

³⁾ Only if ¹⁴C is simulated.

Values in the files above are from the beginning of the step, taken *before* addition of matter and decomposition.

The tabulator-separated data can be read directly by common spreadsheet programs.

The *initial state file* and the *final state file* are written respectively prior to the start of the simulation, and at the end of the simulation. These files contain detailed information concerning system set-up and parameter settings, and should always be checked. See an example of an initial state file in section 6.1.

5. Installation and execution of the program

5.1. Installation

The software can be downloaded from www.agrsci.dk/c-tool/ and is distributed as a zip file

A password for unzipping is required, which will be given upon request by mailing BjornM.Petersen@agrsci.dk. This is done in order to keep track of the users, and in order to be able to mail possible revisions and other informations.

When extracting with WinZip, "Extract to" should be "C:\\" (root), and "Use Folder Names" should be marked. WinZip will then create the directory "\c-tool-v1_1\". The execution file "ctool.exe" is copied to this directory, together with the file "cw3230.dll" and "setup.dat". Under this, subdirectories will also be created, where the input file examples will be stored.

C-TOOL requires a Pentium processor and the Windows 95, Windows 98, Windows ME, Windows NT, Windows 2000 or Windows XP operating system

5.2. Execution

C-TOOL provides a simple interface, which is purely file-driven. If the execution file "ctool.exe" is called without parameters, it will search for the mandatory control file "setup.dat" in the directory "\c-tool-v1_1\". Often it is convenient to place the control file in other directories, and create a batch file with parameter transfer for each specimen of the control file, in the manner described in section 6.1.

The control file specifies both where the remaining input files are found, and where the output files should be written.

6. Execution examples for 3-pool model

The examples presented here take their basis in the Askov long-term field trials (Christensen, 1990; Christensen *et al.*, 1994). All input files shown here are downloaded together with the program (www.agrsci.dk/c-tool/).

A simple three-pool model is utilised for this demonstration (Fig. 6.1). The simulations are primarily intended to be heuristic, and the parameters settings are hence not claimed to be universal.

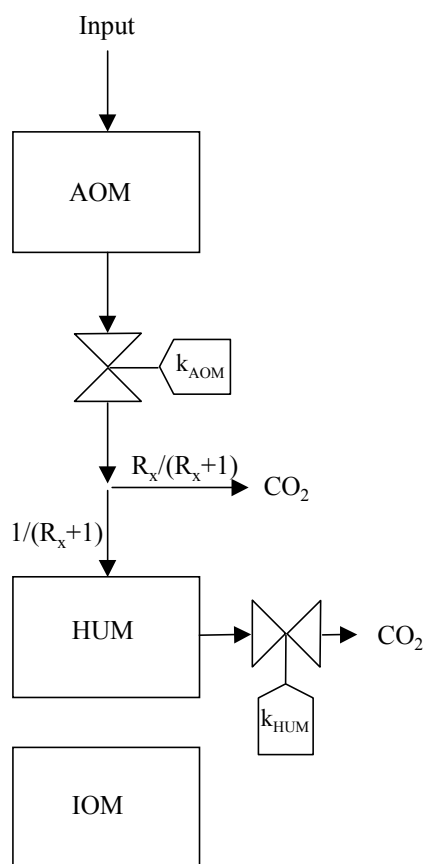

Figure 6.1. Model structure. Boxes are carbon pools, and valves represent decay rates. R_x depends on the clay content, and is calculated according to Eq. 12.

6.1. Input file examples

The model from Fig. 6.1, with its parameters, is defined in the model structure file shown below. Turnover rates are per month.

Model structure file: "\c-tool-v1_1\ThreePoolModel\SimpleModel.dat"

[AddedMatter(0)]

Name	AOM
UseClayEffect	1
DecompositionRate	0.12
Direction(0)	HUM
Fraction(0)	1.0

[Matter(0)]

Name	HUM
DecompositionRate	0.0027
Direction(0)	CO2
Fraction(0)	1.0

[Matter(1)]

Name	IOM
DecompositionRate	0.0 /Totally inert pool
Direction(0)	IOM /Although inert, must point at some pool
Fraction(0)	1.0 /Fractions must add to one

[Parameters]

WaterResponse	0	/Water response not used
ClayResponse	2	/Like Rothc

[end]

The climate file only considers temperature, using monthly averages recorded at the climate station at Askov during 1961-1991.

Microclimate file: "\c-tool-v1_1\ThreePoolModel\climate.dat"

1	1	0.1
2	1	0.1
3	1	2.4
4	1	6.1
5	1	10.7
6	1	13.9
7	1	15.5

8	1	15.7
9	1	12.7
10	1	8.9
11	1	4.4
12	1	1.4

Note that "[end]", which is used to terminate the reading of parameter files, not is used in files with driving variables.

For the examples below, the only type of added organic matter needed to be considered is plant residue. The added organic matter file looks as below

Added organic matter file: "\c-tool-v1_1\ThreePoolModel\addtypes.dat"

```
[OrganicProduct(0)]
Name                PLANTRES
Pool(0)             AOM      /Only one pool that carbon enters
Fraction(0)         1.0

[end]
```

Three set-ups are considered, each with a separate initialisation file.

1) NPK1 plots. This long-term experiment (Lermarken, sandy loam, B2 field, "NPK1" plots) started in 1894. The experiment is given mineral fertiliser, and employs a four- course crop rotation of winter cereals (wheat and rye), root crops (mangolds, sugar beets, turnips and potatoes), spring cereals (barley and oats) and a clover/grass mixture.

Details of the experiment can be seen in Christensen *et al.* (1994).

Initialisation file: "\c-tool-v1_1\ThreePoolModel\npk1\initcond.dat"

```
TotalC            42.2   /t per ha
AOM                0.07
HUM                0.53
HUM.PM            99.4   /This pool is of some average C-14 age
IOM                0.40   /40% of total carbon assumed to be inert
IOM.PM            81.7   /This pool is of substantial average C-14 age
ClayContent        0.12   /12 % clay

[end]
```

The corresponding supply file only consists of one line, as all carbon for convenience is assumed to be returned to the soil in August.

```
Supply file: "\c-tool-v1_1\ThreePoolModel\npk1\added.dat"
```

```
8 1 PLANTRES 3.5
```

An average amount of 3.5 t C ha⁻¹ is assumed to enter the topsoil each year.

2) A purely hypothetical experiment, where a C₄-plant (e.g. maize) was assumed to be grown exclusively since 1950, and to give the same return of C to soil as the C₃-plant crop rotation in 1).

Discrimination of ¹³C occurs in plants, most pronounced in C₃ plants. Field trials where C₄ plants have replaced C₃ plants or vice versa, thus allow for specific tests of model assumptions. The purpose of this example is to demonstrate the potentials of ¹³C discrimination for model validation.

```
Initialisation file: "\c-tool-v1_1\ThreePoolModel\carbon13\initcond.dat"
```

```
TotalC      42.2
AOM          0.04
HUM          0.56
IOM          0.40
AOM.d13C    -29      /Initial dC-13 in the soil is -29
HUM.d13C    -29
IOM.d13C    -29
ClayContent  0.12
```

```
[end]
```

```
Supply file: "\c-tool-v1_1\ThreePoolModel\carbon13\added.dat"
```

```
8 1 PLANTRES 3.5 -12
```

A δ¹³C value of -12 is assumed for carbon from maize residues.

3) Same experiment as 1), but with all incoming carbon being "tagged". Here this is used to assess which fraction of the carbon present at the initiation of the experiment, which was substituted by new matter during the experiment.

The "tagging" option can also be used to analyse internal flow properties, see Petersen *et al.* (2002).

```
Initialisation file: "\c-tool-v1_1\ThreePoolModel>tag\initcond.dat"
```

```
TotalC      42.2
AOM          0.04
HUM          0.56
IOM          0.40 /All untagged by default
ClayContent  0.12
```

```
[end]
```

```
Supply file: "\c-tool-v1_1\ThreePoolModel>tag\added.dat"
```

```
8 1 PLANTRES 3.5 1
```

```
The added matter is "tagged"
```

The control file for the three simulations is seen below:

```
Control file: "\c-tool-v1_1\ThreePoolModel\setup.dat"
```

```
[run(0)]
InputDirectory  \c-tool-v1_1\ThreePoolModel\npk1\
OutputDirectory \c-tool-v1_1\ThreePoolModel\npk1\
MicroClimateFile climate.dat
SupplyFile      added.dat
StructureFile   SimpleModel.dat
AddTypeFile     addtypes.dat
ConditionFile   initcond.dat
DetailFile      details.dat
StartYear       1894
EndYear         2000
UseAverageAmounts Y
UseAverageClimate Y
UseRungeKutta   Y
IsotopeType     2 /Carbon-14
UsePercentModern Y

[run(1)]
InputDirectory  \c-tool-v1_1\ThreePoolModel\carbon13\
OutputDirectory \c-tool-v1_1\ThreePoolModel\carbon13\
MicroClimateFile climate.dat
```

```

SupplyFile          added.dat
StructureFile       SimpleModel.dat
AddTypeFile         addtypes.dat
ConditionFile       initcond.dat
DetailFile          details.dat
StartYear           1950
EndYear             2000
UseAverageAmounts  Y
UseAverageClimate  Y
UseRungeKutta      Y
IsotopeType         1 /Carbon-13

[run(2)]
InputDirectory      \c-tool-v1_1\ThreePoolModel\tag\
OutputDirectory     \c-tool-v1_1\ThreePoolModel\tag\
MicroClimateFile    climate.dat
SupplyFile          added.dat
StructureFile       SimpleModel.dat
AddTypeFile         addtypes.dat
ConditionFile       initcond.dat
DetailFile          details.dat
StartYear           1950
EndYear             2000
UseAverageAmounts  Y
UseAverageClimate  Y
UseRungeKutta      Y
IsotopeType         3 /TAG
ReadTAG             Y /Read TAG value from addfile

[end]

```

Often the most convenient way to run C-TOOL is from a batch file, placed in the same directory as the control file "setup.dat". By doing this each group of simulations can have their own directory, with a specimen of the control file. The present simulations were executed via the batch file shown below, which transfers the directory name to the program.

```
Batch file: "\c-tool-v1_1\ThreePoolModel\c-tool.bat"
```

```
\c-tool-v1_1\ctool \c-tool-v1_1\ThreePoolModel\
```

6.2. Execution results

The initial state file of example 1) is seen below:

Initial state file: "\\c-tool-v1_1\ThreePoolModel\npk1\initstat.txt"

Total carbon amount: 42.2
Using average added amounts
Using average microclimate
StartYear set to 1894
EndYear set to 2000
Fourth order Runge-Kutta integration used
Kirschbaum type temperature response used
TemperatureAdjust 7.24
Kirschbaum1 -3.432
Kirschbaum2 0.168
KirschbaumTopt 36.9
Water responses not used
Carbon-14 simulation
Half time 5568 years
Potential clay effect according to RothC-26.3. Value is 4.13
ClayParameter1 3.09
ClayParameter2 2.672
ClayParameter3 -7.86

----- POOL CONTENTS -----

Type of pool	AddedMatter
Name of pool	AOM
Carbon content	2.954 (100 PM)
Clay effect is	ON
Number of connections 1:	
0: HUM. Allocation fraction:	1
Number of sub-pools 1:	
Type of pool	AOM
Name of pool	AOM-subpool
Carbon content	2.954
Decomposition rate	0.12
Clay effect is	ON
Type of pool	Matter
Name of pool	HUM
Carbon content	22.37 (99.4 PM)
Decomposition rate	0.0027
Number of connections 1:	
0: CO2. Allocation fraction:	1
Type of pool	Matter
Name of pool	IOM
Carbon content	16.88 (81.7 PM)
Decomposition rate	0
Number of connections 1:	
0: IOM. Allocation fraction:	1

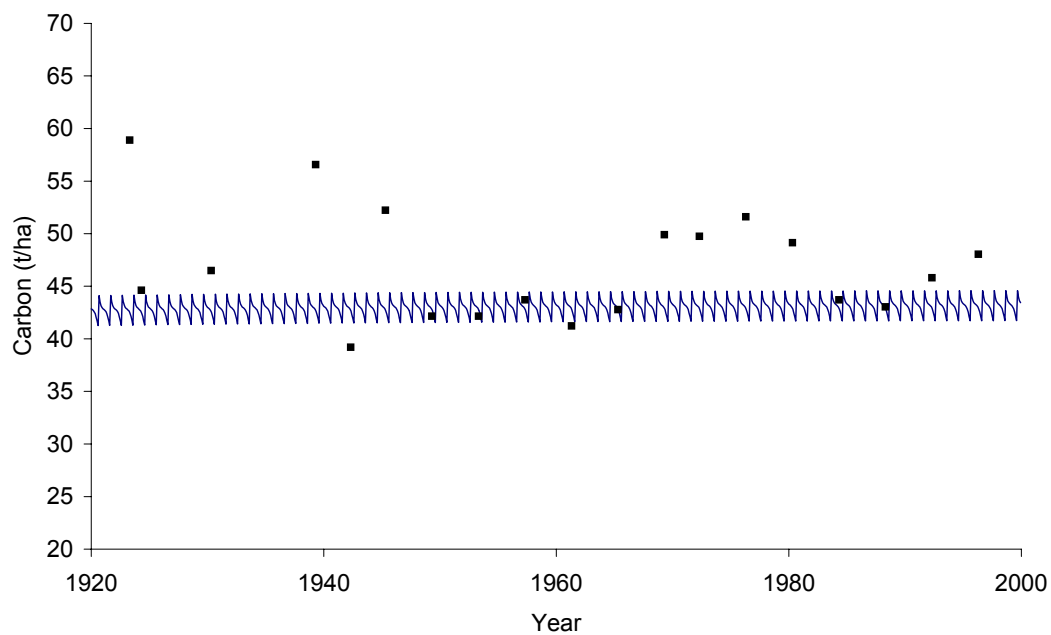

Figure 6.2.1. Organic C in soil (0-20 cm) from the Askov Long-term Fertilizer Experiments, Lermarken, B2 field, NPK1 plots, as measured (■) and modelled (line).

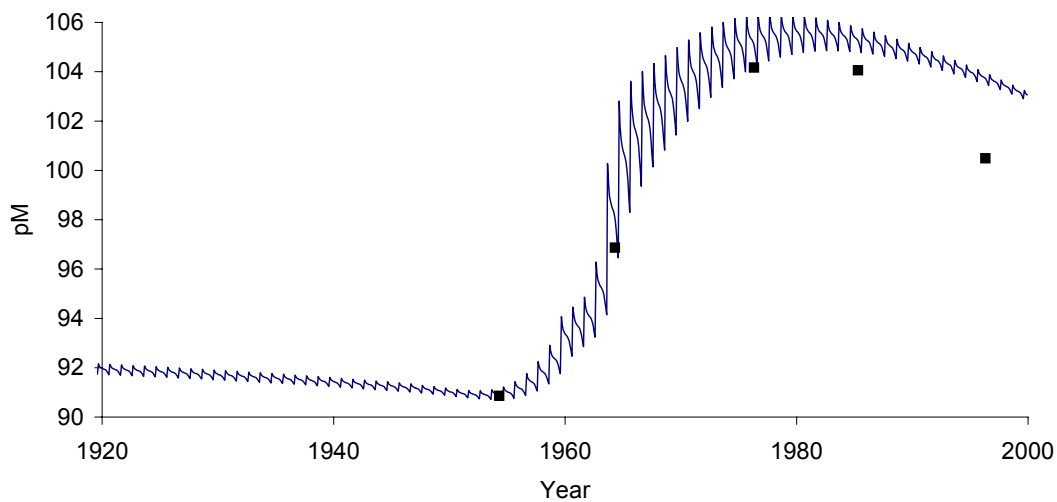

Figure 6.2.2. Radiocarbon content in soil (0-20 cm, "absolute" percent modern) from the Askov Long-term Fertilizer Experiments, as measured (■) and modelled (line). Field B2, NPK1 treatment.

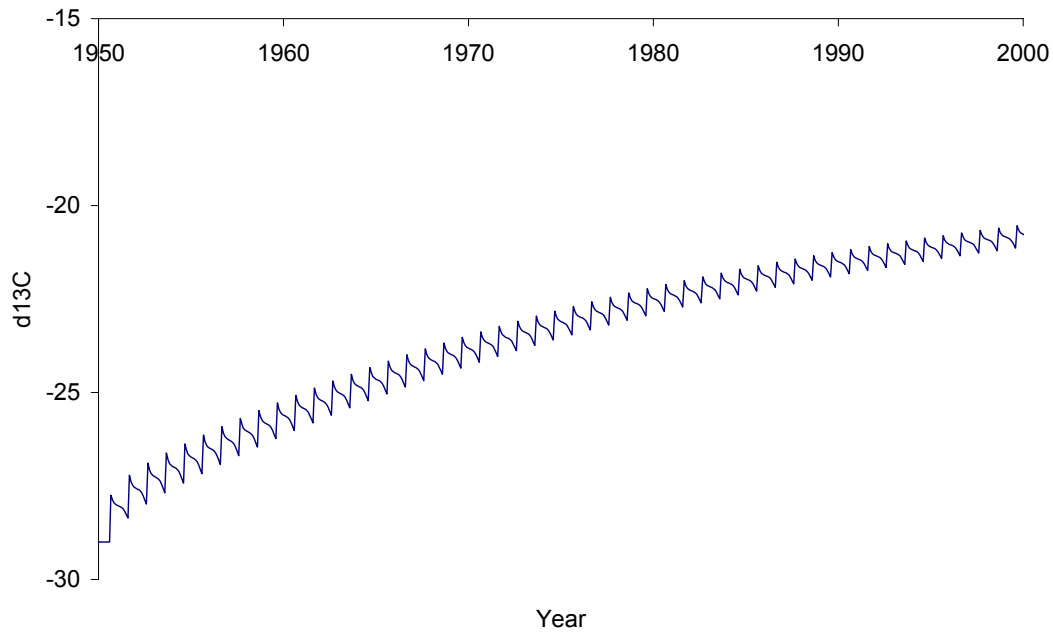

Figure 6.2.3. Hypothetical ^{13}C content in soil with carbon input levels as in Fig. 6.2.1, but using C_4 plants from 1950.

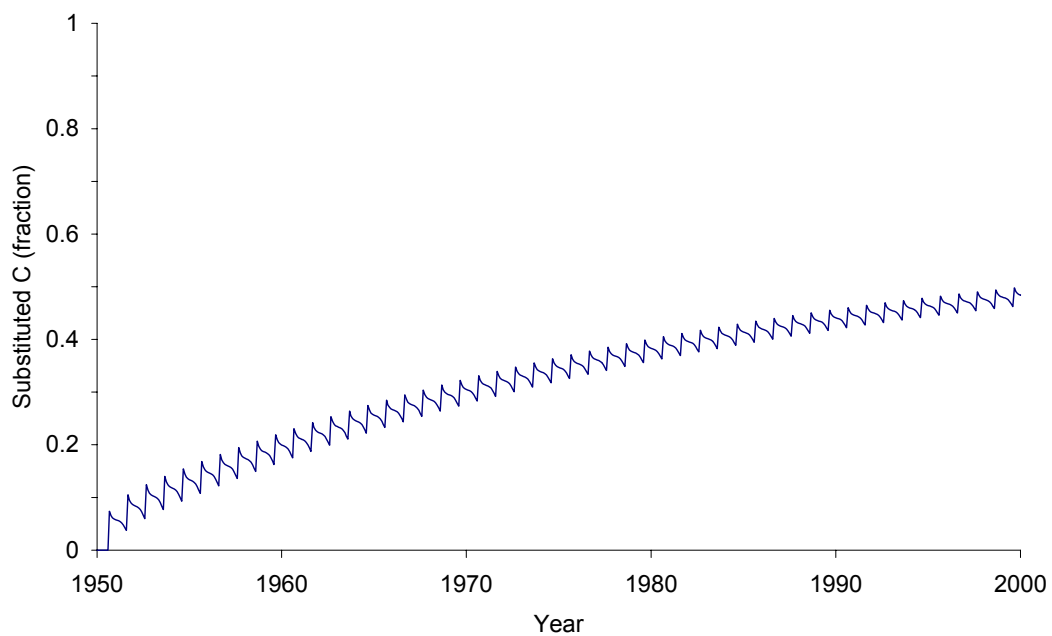

Figure 6.2.4. Hypothetical "tagged" fraction in soil with carbon input levels as in Fig. 6.2.1. The "tagged" fraction corresponds to the fraction of the original C content that is substituted during the simulation period.

7. Execution examples for CN-SIM

The model CN-SIM (Fig. 7.1) and the following simulation examples are taken from Petersen *et al.* (2003). All the necessary input files are downloaded together with the program (www.agrsci.dk/c-tool/). CN-SIM is developed on the basis of a large number of experiments, utilising automated non-linear optimisation for parameter estimation.

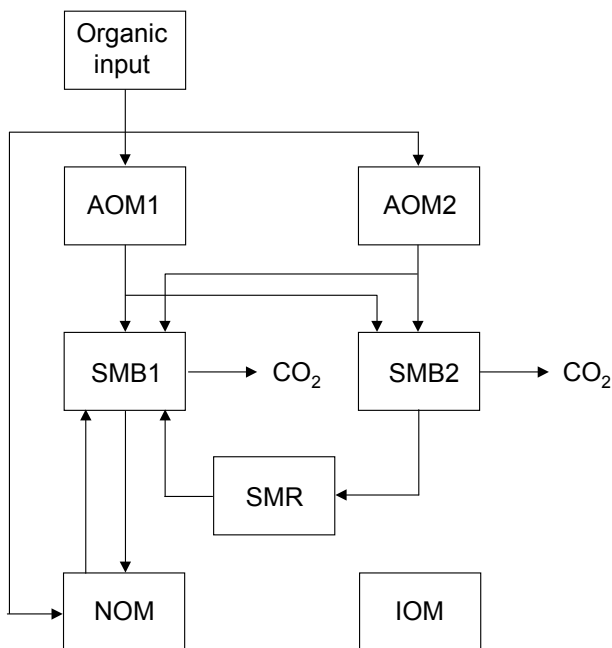

Figure 7.1. Carbon flows in the 7-pool model CN-SIM. AOM1 and AOM2 are added organic matter pools, SMB1 and SMB2 are microbial biomass pools, SMR is a microbial residue pool, NOM is the “humus” pool, and IOM is an inactive pool.

The model from Fig. 7.1., including its parameters, is defined in the model structure file shown below. Turnover rates are per month.

Model structure file: "\c-tool-v1_1\CN-SIM\CN-SIM.dat"

```
[AddedMatter(0)]
Name                AOM1
DecompositionRate   0.122
Direction(0)        SMB2
Fraction(0)         0.688
Direction(1)        SMB1
Fraction(1)         0.312

[AddedMatter(1)]
Name                AOM2
DecompositionRate   1.22
Direction(0)        SMB2
Fraction(0)         0.688
Direction(1)        SMB1
Fraction(1)         0.312

[BioMatter(0)]
Name                SMB1
UseClayEffect       1
UtilizationEfficiency 0.6
DeathRate           0.168
Maintenance         0.194
Direction(0)        NOM
Fraction(0)         1.0

[BioMatter(1)]
Name                SMB2
UseClayEffect       1
UtilizationEfficiency 0.6
DeathRate           2.05
Maintenance         1.84
Direction(0)        SMR
Fraction(0)         1.0

[Matter(0)]
Name                SMR
UseClayEffect       1
DecompositionRate   0.134
Direction(0)        SMB1
Fraction(0)         1.0

[Matter(1)]
Name                NOM
DecompositionRate   0.004438
Direction(0)        SMB1
Fraction(0)         1.0

[Matter(2)]
Name                IOM
DecompositionRate   0.0    /Considered inert
Direction(0)        IOM
Fraction(0)         1.0

[Parameters]
ClayResponse        3
ClayParameter4      1.67  /Set according to RothC
TemperatureResponse  1      /Kirschbaum temperature response type
WaterResponse        2      /Read directly from file

[end]
```

The climate files for Askov consider an “average” water effect, calculated according to Petersen *et al.* (2003). This effect differs between bare fallow and crop rotation.

For the bare fallow, the climate file is as follows.

Microclimate file: "\c-tool-v1_1\CN-SIM\askov_bares_month.dat"

1	1	0.1	0.96
2	1	0.1	0.96
3	1	2.4	0.96
4	1	6.1	0.96
5	1	10.7	0.96
6	1	13.9	0.96
7	1	15.5	0.96
8	1	15.7	0.96
9	1	12.7	0.96
10	1	8.9	0.96
11	1	4.4	0.96
12	1	1.4	0.96

The climate file for the crop rotation has a slightly lower value for the water effect, due to a higher evapotranspiration.

Microclimate file: "\c-tool-v1_1\CN-SIM\askov_month.dat"

1	1	0.1	0.91
2	1	0.1	0.91
3	1	2.4	0.91
4	1	6.1	0.91
5	1	10.7	0.91
6	1	13.9	0.91
7	1	15.5	0.91
8	1	15.7	0.91
9	1	12.7	0.91
10	1	8.9	0.91
11	1	4.4	0.91
12	1	1.4	0.91

When using CN-SIM on other locations, a water effect value must be determined. When daily climate data are available, this can be done according to Petersen *et al.* (2003). If daily climate data are not available, and the site is exposed to temperate, humid climate, the above values can be used as proximates for the water effect. If the soil is very light-textured, a value of 0.85 may be more appropriate for vegetated soil (Petersen *et al.*, 2003). This model is only calibrated on agricultural soils with temperate, humid climate, and should only be used with great caution on other types of land use or climate.

For the examples below, two types of added organic matter need to be considered: plant residue and animal manure. The added organic matter file looks as below

Added organic matter file: "\c-tool-v1_1\CN-SIM\addtypes.dat"

[OrganicProduct(0)]

Name	PLANT
Pool(0)	AOM1
Fraction(0)	0.45
DecayRate(0)	0.122
Pool(1)	AOM2
Fraction(1)	0.55
DecayRate(1)	1.22

[OrganicProduct(1)]

Name	FYM
Pool(0)	AOM1
Fraction(0)	0.297
DecayRate(0)	0.091
Pool(1)	AOM2
Fraction(1)	0.500
DecayRate(1)	1.22
Pool(2)	NOM
Fraction(2)	0.203

[end]

All five Askov-simulations from Petersen *et al.* (2003) are considered, each with a separate initialisation file.

1) "ASKOV-FL1-B3": Fallowed plots from Askov B3 field, including radiocarbon simulation. These plots were kept bare by mechanical weeding during 1956-1985, see (Christensen, 1990) for details.

Initialisation file: "\c-tool-v1_1\CN-SIM\Baresoil_b3\initcond_bares_b3.dat"

TotalC	53.8	/t C per ha
ClayContent	0.12	/kg per kg
AOM1	0.027	
AOM2	0.000	
SMB1	0.016	
SMB2	0.001	
SMR	0.019	
NOM	0.532	
NOM.PM	99.4	
IOM	0.405	
IOM.PM	80.5	

[end]

Supply file: "\c-tool-v1_1\CN-SIM\soilinp_bares.dat"

4	1	PLANT	0.07
5	1	PLANT	0.10
6	1	PLANT	0.14
7	1	PLANT	0.54

An average amount of 0.85 t C ha⁻¹ is assumed to enter the topsoil each year. The bare soil supply file is common for all three bare fallow simulations.

2) "ASKOV-FL1-B4": Fallowed plots from Askov B4 field. These plots were kept bare by mechanical weeding during 1956-1985, see (Christensen, 1990) for details. Supply file shared with 1).

Initialisation file: "\c-tool-v1_1\CN-SIM\Baresoil_b4\initcond_bares_b4.dat"

TotalC	49.3	/t C per ha
ClayContent	0.12	/kg per kg
AOM1	0.027	
AOM2	0.000	
SMB1	0.016	
SMB2	0.001	
SMR	0.019	
NOM	0.532	
IOM	0.405	

[end]

3) “ASKOV-FL2”: Fallowed frames from Askov, including radiocarbon simulation. These frames were kept bare by mechanical weeding during 1956-1986, see (Christensen, 1988) for details. Supply file shared with 1).

Initialisation file: "\c-tool-v1_1\CN-SIM\frame_bare\initcond_frame_bares.dat"

TotalC	116.8	/t C per ha
ClayContent	0.098	/kg per kg
AOM1	0.027	
AOM2	0.000	
SMB1	0.016	
SMB2	0.001	
SMR	0.019	
NOM	0.532	
NOM.PM	99.4	
IOM	0.405	
IOM.PM	77.4	

[end]

4) “ASKOV-NPK”: This long-term experiment (Lermarken, sandy loam, B2 field, "NPK1" plots) started in 1894. The experiment is given mineral fertiliser, and employs a four- course crop rotation of winter cereals (wheat and rye), root crops (mangolds, sugar beets, turnips and potatoes), spring cereals (barley and oats) and a clover/grass mixture.

Details of the experiment can be seen in Christensen *et al.* (1994).

Initialisation file: "\c-tool-v1_1\CN-SIM\ NPK1_B2\initcond_npk1.dat"

TotalC	42.2	/t C per ha
ClayContent	0.12	/kg per kg
AOM1	0.027	
AOM2	0.000	
SMB1	0.016	
SMB2	0.001	
SMR	0.019	
NOM	0.532	
NOM.PM	99.4	
IOM	0.405	
IOM.PM	78.3	

[end]

Supply file: "\c-tool-v1_1\CN-SIM\ NPK1_B2\meaninp_npk1.dat"

4	1	PLANT	0.28
5	1	PLANT	0.42
6	1	PLANT	0.57
7	1	PLANT	2.26

An average amount of 3.53 t C ha⁻¹ is assumed to enter the topsoil each year.

5) "ASKOV-FYM": This long-term experiment (Lermarken, sandy loam, B2 field, "FYM1" plots) started in 1894. The experiment is given animal manure, and employs a four- course crop rotation of winter cereals (wheat and rye), root crops (mangolds, sugar beets, turnips and potatoes), spring cereals (barley and oats) and a clover/grass mixture.

Details of the experiment can be seen in Christensen *et al.* (1994).

Initialisation file: "\c-tool-v1_1\CN-SIM\Fym1_b2\initcond_fym1.dat"

TotalC	47.7	/t C per ha
ClayContent	0.12	/kg per kg
AOM1	0.027	
AOM2	0.000	
SMB1	0.016	
SMB2	0.001	
SMR	0.019	
NOM	0.532	
NOM.PM	99.4	

IOM 0.405
IOM.PM 79.4

[end]

Supply file: "\c-tool-v1_1\CN-SIM\ NPK1_B2\meaninp_npk1.dat"

4 1 PLANT 0.25
5 1 PLANT 0.37
6 1 PLANT 0.49
7 1 PLANT 1.97
9 1 FYM 1.0

An average amount of 3.08 t C ha⁻¹ from crop residues and 1.0 t C ha⁻¹ from animal manure is assumed to enter the topsoil each year.

The control file for the five simulations is seen below:

Control file: "\c-tool-v1_1\CN-SIM\setup.dat"

```
[run(0)]
InputDirectory \c-tool-v1_1\CN-SIM\npk1_b2\
OutputDirectory \c-tool-v1_1\CN-SIM\npk1_b2\
MicroClimateFile askov_month.dat
SupplyFile meaninp_npk1.dat
StructureFile CN-SIM.dat
AddTypeFile addtypes.dat
ConditionFile initcond_npk1.dat
DetailFile details.txt
UseAverageAmounts Y
UseAverageClimate Y
UseRungeKutta Y
StartYear 1953
EndYear 2000
IsotopeType 2 /14C
UsePercentModern Y
```

```
[run(1)]
InputDirectory \c-tool-v1_1\CN-SIM\fym1_b2\
OutputDirectory \c-tool-v1_1\CN-SIM\fym1_b2\
MicroClimateFile askov_month.dat
SupplyFile meaninp_fym1.dat
StructureFile CN-SIM.dat
AddTypeFile addtypes.dat
ConditionFile initcond_fym1.dat
DetailFile details.txt
UseAverageAmounts Y
UseAverageClimate Y
UseRungeKutta Y
StartYear 1953
EndYear 2000
IsotopeType 2 /14C
UsePercentModern Y
```

```

[run(2)]
InputDirectory      \c-tool-v1_1\CN-SIM\BareSoil_b3\
OutputDirectory     \c-tool-v1_1\CN-SIM\BareSoil_b3\
MicroClimateFile    askov_bares_month.dat
SupplyFile          soilinp_bares.dat
StructureFile       CN-SIM.dat
AddTypeFile         addtypes.dat
ConditionFile       initcond_bares_b3.dat
DetailFile          details.txt
UseAverageAmounts  Y
UseAverageClimate   Y
UseRungeKutta      Y
StartYear           1956
EndYear             1985
IsotopeType         2 /14C
UsePercentModern    Y

```

```

[run(3)]
InputDirectory      \c-tool-v1_1\CN-SIM\BareSoil_b4\
OutputDirectory     \c-tool-v1_1\CN-SIM\BareSoil_b4\
MicroClimateFile    askov_bares_month.dat
SupplyFile          soilinp_bares.dat
StructureFile       CN-SIM.dat
AddTypeFile         addtypes.dat
ConditionFile       initcond_bares_b4.dat
DetailFile          details.txt
UseAverageAmounts  Y
UseAverageClimate   Y
UseRungeKutta      Y
StartYear           1956
EndYear             1985

```

```

[run(4)]
InputDirectory      \c-tool-v1_1\CN-SIM\frame_bare\
OutputDirectory     \c-tool-v1_1\CN-SIM\frame_bare\
MicroClimateFile    askov_bares_month.dat
SupplyFile          soilinp_bares.dat
StructureFile       CN-SIM.dat
AddTypeFile         addtypes.dat
ConditionFile       initcond_frame_bares.dat
DetailFile          details.txt
UseAverageAmounts  Y
UseAverageClimate   Y
UseRungeKutta      Y
StartYear           1956
EndYear             1987
IsotopeType         2 /14C
UsePercentModern    Y

```

[end]

The present simulations were executed via the batch file below, which transfers the directory name to the program.

Batch file: "\c-tool-v1_1\CN-SIM\c-tool.bat"

\c-tool-v1_1\ctool \c-tool-v1_1\CN-SIM\

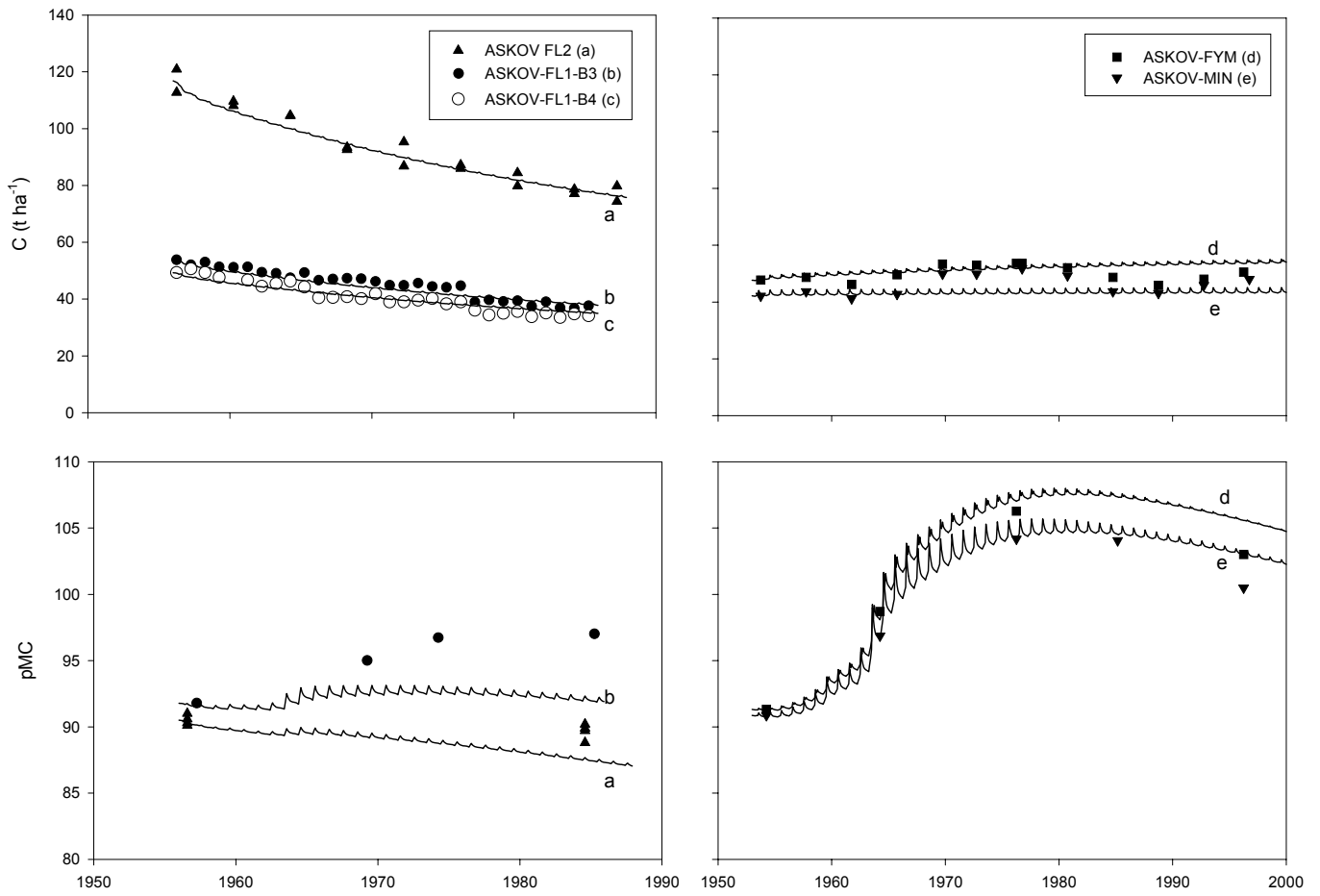

Figure 7.2. Measurements (symbols) and simulations (lines) of soil C and ¹⁴C in % modern (0-20 cm depth) from selected treatments from Askov. Askov bare fallow (ASKOV-FL1-B3, ASKOV-FL1-B4 and ASKOV-FL2) are shown left. Data from the crop rotations ASKOV-FYM and ASKOV-MIN are shown right.

8. References

- Baxter, M.S. and Walton, A., 1971. Fluctuations of atmospheric carbon-14 during the past century. *Proc. Roy. Soc. London, A.* **321**: 105-127.
- Christensen, B.T., 1988. Effect of cropping system on the soil organic matter content. I. Small plot experiments with incorporation of straw and animal manure, 1956-1986 (in Danish with English summary). *Tidsskr. Planteavl* **92**, 295-305.
- Christensen, B.T. 1990. Sædskiftets indflydelse på jordens indhold af organisk stof. II. Markforsøg på grov sandblandet lerjord (JB5), 1956-1985 (in Danish with English summary). *Tidsskr. Planteavl* **94**: 161-169.
- Christensen, B.T., Petersen, J., Kjellerup, V. and Trentemøller, U. 1994. The Askov Long-Term Experiments on Animal Manure and Mineral Fertilizers: 1894-1994. Ministry of Agriculture. Danish Institute of Plant and Soil Science. SP report no 43.
- Coleman, K. and Jenkinson, D.S., 1996. RothC-26.3. A model for the turnover of carbon in soil. In: D.S. Powlson, P. Smith and J.U. Smith (Editors), Evaluation of Soil Organic Matter Models Using Existing, Long-Term Datasets, NATO ASI series I, Vol 38, Springer-Verlag, Heidelberg, pp 237-246.
- Hansen, S., Jensen, H.E., Nielsen, N.E. and Svendsen, H., 1990. DAISY – soil plant atmosphere system model. NPo forskning fra Miljøstyrelsen. A10, Miljøministeriet, Copenhagen, 272 pp.
- Johnsson, H., Bergström, L., Jansson, P.E. and Paustian, K., 1987. Simulation of nitrogen dynamics and losses in a layered agricultural soil. *Agric. Ecosyst. Environ.* **18**: 333-356.
- Kirschbaum, M.U.F., 1995. The temperature dependence of soil organic matter decomposition, and the effect of global warming on soil organic C storage. *Soil Biol. Biochem.* **27**: 753-760.
- Levin, I. and Kromer, B., 1997. Twenty years of atmospheric $^{14}\text{CO}_2$ observations at Schauinsland station, Germany. *Radiocarbon* **39**: 205-218.
- Levin, I., Kromer, B., Schoch-Fischer, H., Bruns, M., Münnich, M., Berdau, D., Vogel, J.C. and Münnich, K.O. 1994. $\Delta^{14}\text{C}$ records from sites in Central Europe. In: Boden, T.A., Kaiser, D.P., Sepanski, R.J. and Stoss, F.W. (Editors). Trends '93: A compendium of Data on Global Change. ORNL/CDIAC-65. Carbon Dioxide Information Analysis Center, Oak Ridge National Laboratory, Oak Ridge, Tenn., USA, pp. 203-222.

- Petersen, B.M., Berntsen, J., Hansen, S. and Jensen, L.S. 2003. CN-SIM - a model for the turnover of soil organic matter. I: Long-term carbon and radiocarbon development. Submitted to *Soil Biol. Biochem.*
- Petersen, B.M., Olesen, J.E. and Heidmann, T. 2002. A flexible tool for simulation of soil carbon turnover. *Ecological Modelling* **151**: 1-14.
- Stuiver, S. and Polach, H.A. 1977. Reporting of ^{14}C data. *Radiocarbon* **19**: 355-363.